

## VALVE CONTROL PRODUCTS

# GUARD VALVE® SERIES

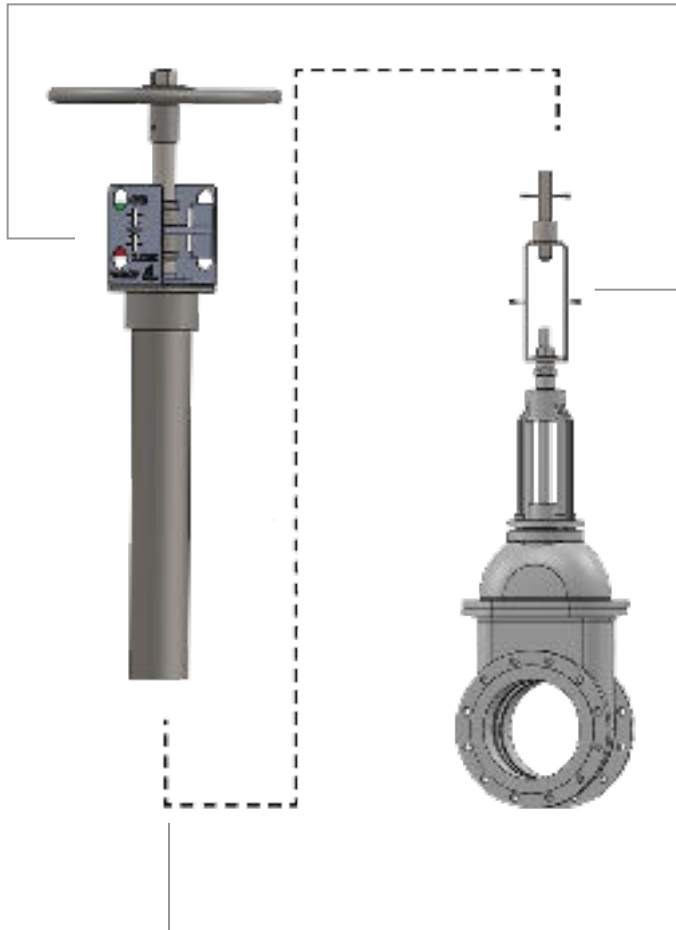

**VALVE CONTROL** AND INDICATOR FOR NON-RISING STEM SUBMERGED CARGO AND BALLAST VALVES.

INTEGRAL STUFFING BOX WITH TRIPLE SEAL (TEFLON AND VITON).

**ZERO WEIGHT** ON VALVE HEAD ALL WEIGHT DISTRIBUTED ON STUFFING BOX, STANDPIPE AND TANK TOP.

ACCEPTS VALVES WITH 15-25 TURNS.

BERGAN SLIP YOKE ALLOWS FOR THE YOKE TO BE UNBOLTED, SLIPPED OUT OF THE WAY, AND RE-PINNED.

**DIRECT WELDING** TO 3" OR 4" PIPE.

AVAILABLE FLANGE MOUNTING.

AVAILABLE REACH RODS IN SIZE (1", 1-1/4", AND 1-1/2") STEM ADAPTER AND HAND WHEELS.

SLIP YOKE ALLOW FOR EASY CHANGE OUT OF VALVE.

The GUARD VALVE® series of products are designed for manual control of non-rising submerged cargo and ballast valves and give a clear indication of the valve position even from afar.

The main components are a heavy-duty stainless-steel handwheel, a deck stand with attached valve position indication and stuffing box, a reach rod and a stainless-steel yoke with appropriate sizes for direct fitting to the valve stem. All parts can be customized to meet any requirements.

The deck stand and associated valve position indication can be welded directly to the deck plate or, if required, be fitted for a flanged connection (three or four inches).

Unique features include a DELRIN® thrust bearing which eliminates weight and associated wear on the valve. And, with the sliding yoke assembly design, the valve can be replaced without lifting the reach rod assembly.



**BERGAN**  
MARINE SYSTEMS

850.434.1286

SALES@BERGANMARINESYSTEMS.COM

BERGANMARINESYSTEMS.COM